



By Gun Pro™

Sight Installation Guide For 1911 and Glocks

**PLEASE READ AND UNDERSTAND ALL INSTRUCTIONS AND WARNINGS
BEFORE USE AND INSTALLATION**

If you have fixed sights, some of these instructions will not pertain to you.
For Smith and Wesson M&P, see the M&P Installation Guide

WARNING:

Firearms are classified as dangerous weapons. Injury or death may result from unsafe or improper use. Before installing or adjusting your Delta 1 Sight®, understand and be responsible regarding firearm ownership.

Gun Pro™ strongly advises you to seek the assistance of a reputable gunsmith. Gun Pro™ and its owners or agents will not be held responsible for the result of unauthorized repairs and/or adjustments, or faulty installation. Gun Pro™ and its owners or agents will not be held responsible for careless, unsafe firearm use, or personal injury or property damage of any kind resulting from such use.

It is the responsibility of the user to determine the suitability of the Delta 1 Sight® for any specific use.

- Always treat a firearm as if it were loaded**
- Be sure your firearm is unloaded before making adjustments or installation**
- Never take anyone's word that a firearm is unloaded**
- When a firearm is handed to you, always check that it is unloaded**
- Always keep the muzzle pointed in a safe direction**
- Never point a firearm at an unintended target**
- Never put your hand over the muzzle of a firearm**
- Always keep your firearm unloaded until you intend to shoot**
- Before shooting, make sure of your target and backdrop**
- Always keep your finger(s) off the trigger until aiming at your target and ready to shoot**
- Firearms, alcohol, drugs and certain medications do not mix.**
- Always wear protective eyewear and hearing protection when shooting**

Not all pistols, shooters or ammunition impacts in the same place. Pistols vary, in that even the same model may not shoot to the same point of impact. Ammunition and the individual shooting add an additional variable.

Note to Gunsmith

Read ALL Instructions BEFORE Proceeding

Clean sight dovetail and slide with acetone or alcohol to remove any oil residue.

IMPORTANT! Avoid getting alcohol or acetone on the acrylic Delta or any sight adjustment screws which could possibly damage the acrylic Delta or degrade the thread locking compound.

CAUTION: Acetone is Extremely Flammable!

Fitting is commonly required as dovetails are most often very tight and slides do vary from gun to gun even of same models. All screws are right hand threaded screws including windage screws if applicable. Make sure front and rear dovetail set screws are backed off as to not interfere with installation. Push and drift new sights into dovetails; the direction may depend on gun model and machining. If fitting is required, always start by removing material from bottom of male sight dovetail with fine emery stone, or file. Use a black marker to get a visual where there is interference each time you test fit.

Stoning is accomplished by applying counted strokes on the stone then rotating the sight base 180 degrees and honing the same amount of strokes to remove material evenly.

Measure sight with calipers often and hand test for fit using a black marker for visual interference. Remove residue from dovetails prior to each test fit. Once you can readily see the dovetail will fit snugly and completely, use a non-marring punch and drift the sights in place and center them on the slide.



IMPORTANT! Push or tap ONLY on the base of the dovetail(s). Avoid tapping on the front sight blade or rear sight windage adjustment area if applicable otherwise damage WILL result.

Once the dovetail on the front and rear sight are drifted to center, snugly tighten the primary set screws (see #1 below on the 1911 adjustable sight) with the wrench provided while avoiding over tightening. On the Glock, front sights are installed using a 3/16" hex socket available on line. On the rear sight, tighten the two primary set screws snugly.

Adjustments for Adjustable Sights: Do Not Over Tighten Screws! **Make sure your firearm is unloaded!**

1. Primary set screws for installation.
2. Forward height screw.
3. Rear height screw.
4. Right windage screw.
5. Left windage screw.

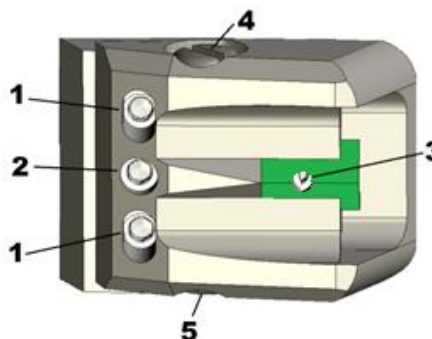

Note for all Gun Pro Sights: If you inadvertently remove a set screw and need to reinsert, we advise inserting from the bottom up.

Notice for Adjustable Sights!

To avoid damage to sight and ensure proper thread contact, follow instructions below
Before making any sight adjustment, loosen opposing screw first, and then tighten intended adjustment screw. Likewise, before adjusting either height screw, loosen one windage screw, make intended adjustment, then retighten all adjustment screws snugly and re-test bullet impact.

Failure to adjust properly

Will result in damage to Acrylic Delta, the sight itself or screws prematurely loosening. !

Detailed sequence for adjustments to move the rear sight in the direction of intended impact
For height, first loosen one windage screw and then simply loosen #2 and tighten #3 to raise impact. Reverse order (do not back #3 into Acrylic) to lower impact then retighten the windage screw previously loosened.
For windage, loosen #4 and tighten #5 to move impact right. Reverse order to move impact left.

Note: It does not take much to make a difference in sight adjustments. For example, with a five inch sight radius and a sight group off one inch from center of intended impact at 25 yards, your adjustment is only five and a half thousandths of an inch.

That is about the thickness of a piece of 24 lb. paper or 0.0055"

Give yourself some repeated range time to make sure you are shooting at the same point of impact and make corrections accordingly. Periodically check sights to make sure adjustment stays tight. Once they are set, leave them alone and practice.

ND VC-3 thread adhesive has been pre-applied by Gun Pro on the 1911 sights only. Fixed sights have adhesive included and can be applied by user if preferred, however, if new or more thread adhesive is to be applied, remove and clean screws and sight threads with acetone or alcohol to remove any and all oil residue. DO NOT get acetone on the acrylic Delta, damage will result. Then follow instructions provided here:

Knead package well before each use. Apply VC-3 a length of 1 to 1½ times the fastener diameter, filling threads 50-100%. Although material will be dry to touch within minutes, allow VC-3 to dry for 10-30 minutes (the longer the better), depending on part size. Fasteners are then ready for assembly.

 **CAUTION**  **ND VC-3 Adhesive is Flammable, keep from sparks and open flame. Keep screw adhesive away from children. NOT for human consumption. See Material Safety Data Sheet at www.GunPro.us**

Gun Pro Front Sight Coating

Gun Pro's Front sights come standard with a hard smooth fusion bonded Thermoplastic **Blaze Orange** coating. Front sights are also available with standard uncoated serrations at a minimal cost.

If painting is desired, clean sight area to be painted with acetone or alcohol to remove any oil residue. DO NOT get acetone on the acrylic Delta, damage will result. Avoid getting acetone on any sight adjustment screws which could possibly degrade the thread locking compound.

CAUTION: Alcohol and Acetone is Flammable!



Redefining Performance

